

① SCALE: 1/4" = 1'-0"

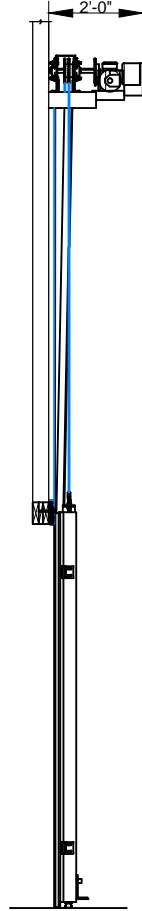

②

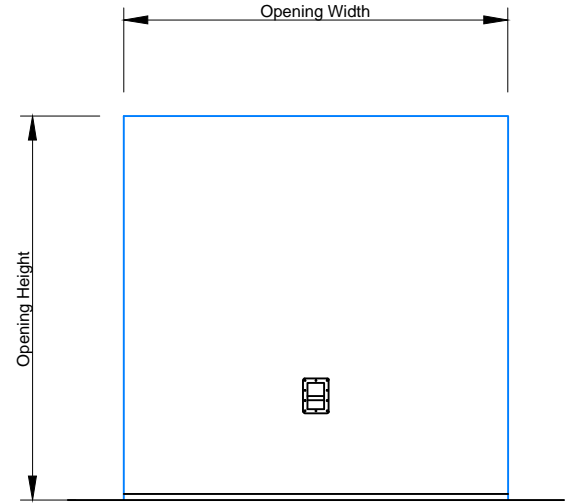

③ SCALE: 1/4" = 1'-0"

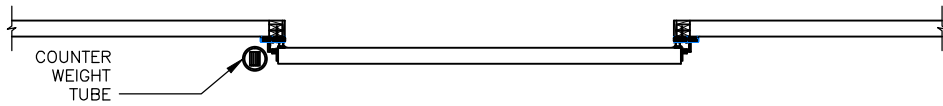

④ SCALE: 1/4" = 1'-0"

- ① ELEVATION – SWEEP BOTTOM VERTICAL DOOR (EXTERIOR)
- ② SECTION – SWEEP BOTTOM VERTICAL DOOR
- ③ ELEVATION – SWEEP BOTTOM VERTICAL DOOR (INTERIOR)
- ④ JAMB – SWEEP BOTTOM VERTICAL DOOR

Vertical Lift Door with Face Casings

Model EFD-VLE

Left-Hand Counterweight

Exterior Pull Handle with Interior Recessed Handle

ALL DRAWINGS ARE 1/4" = 1'-0" SCALE UNLESS OTHERWISE NOTED



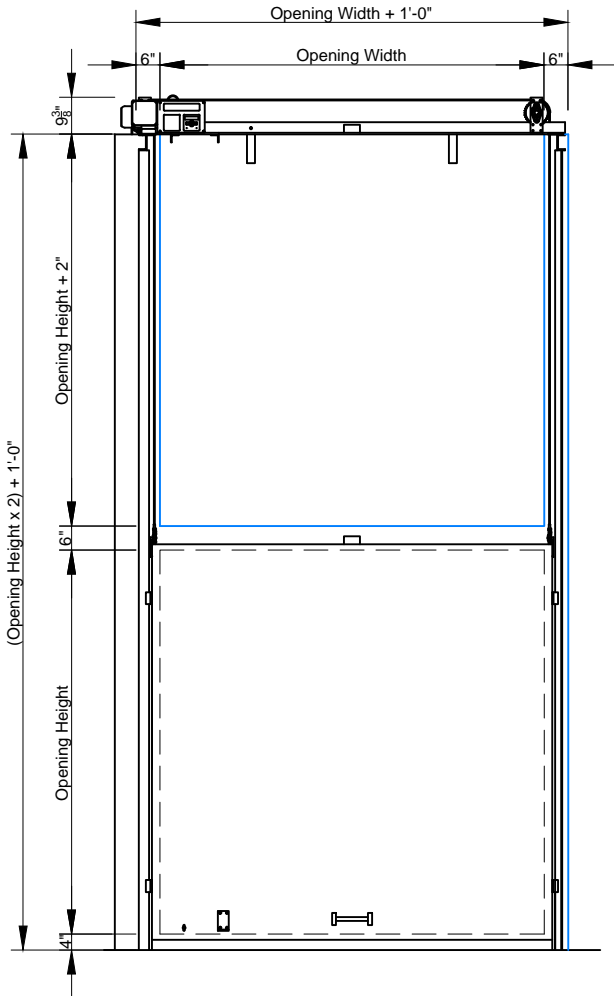

⑤ SCALE: 1/4" = 1'-0"

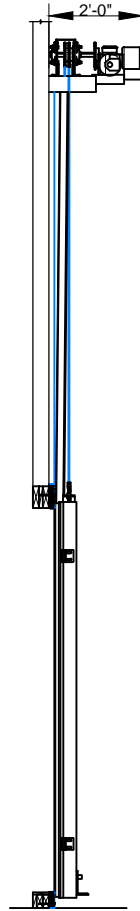

⑥

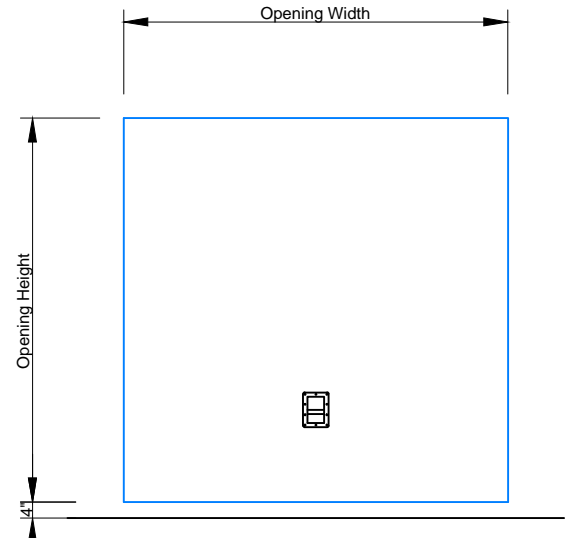

⑦ SCALE: 1/4" = 1'-0"

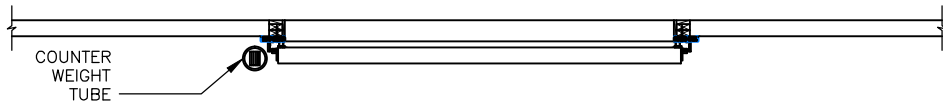

⑧ SCALE: 1/4" = 1'-0"

- ⑤ ELEVATION – HIGH SILL STEP OVER VERTICAL DOOR (EXTERIOR)
- ⑥ SECTION – HIGH SILL STEP OVER VERTICAL DOOR
- ⑦ ELEVATION – HIGH SILL STEP OVER VERTICAL DOOR (INTERIOR)
- ⑧ JAMB – HIGH SILL STEP OVER VERTICAL DOOR

ALL DRAWINGS ARE 1/4" = 1'-0" SCALE UNLESS OTHERWISE NOTED



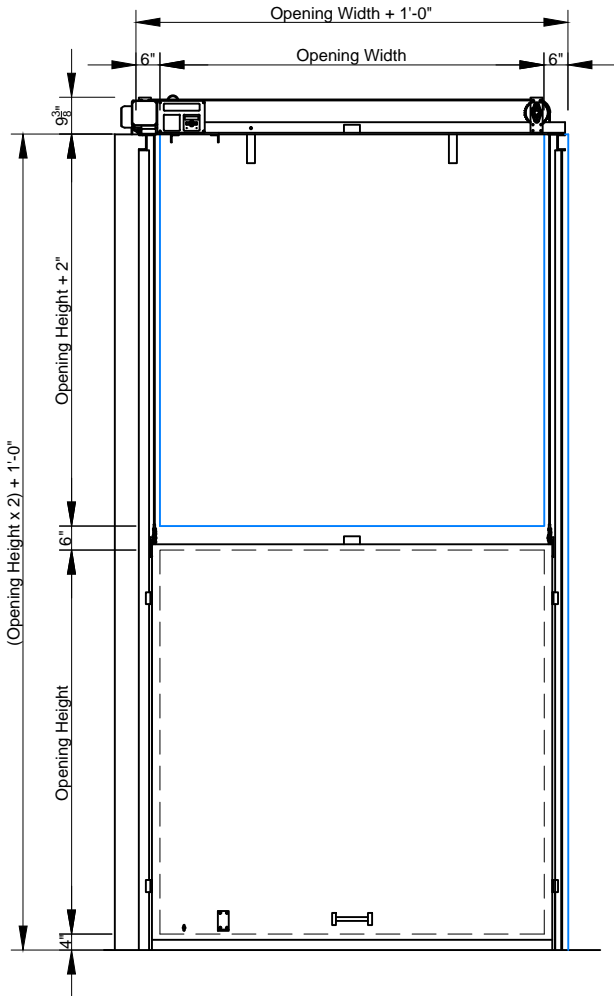

⑨ SCALE: 1/4" = 1'-0"

⑩

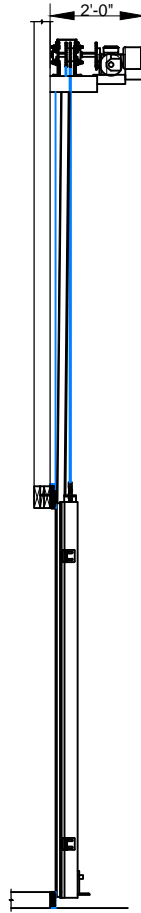

⑪ SCALE: 1/4" = 1'-0"

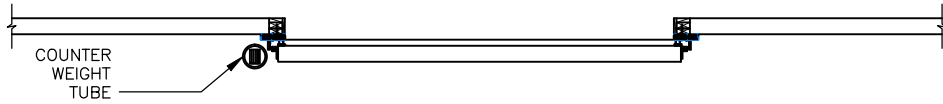
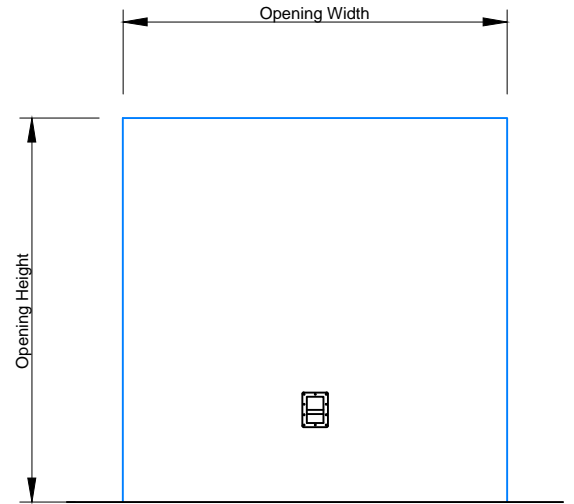

⑫ SCALE: 1/4" = 1'-0"

- ⑨ ELEVATION – HIGH SILL VERTICAL DOOR (EXTERIOR)
- ⑩ SECTION – HIGH SILL VERTICAL DOOR
- ⑪ ELEVATION – HIGH SILL VERTICAL DOOR (INTERIOR)
- ⑫ JAMB – HIGH SILL VERTICAL DOOR

ALL DRAWINGS ARE 1/4" = 1'-0" SCALE UNLESS OTHERWISE NOTED



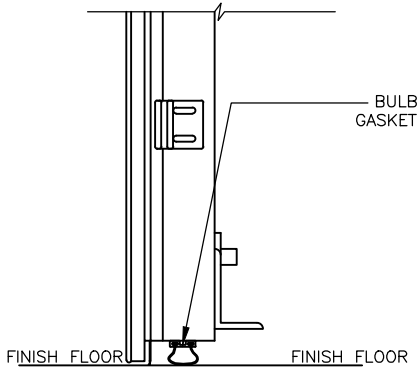

⑬ SCALE: 1" = 1'-0"

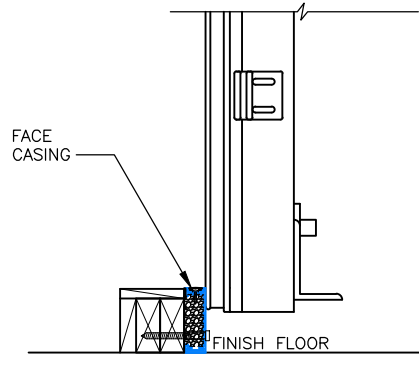

⑭ SCALE: 1" = 1'-0"

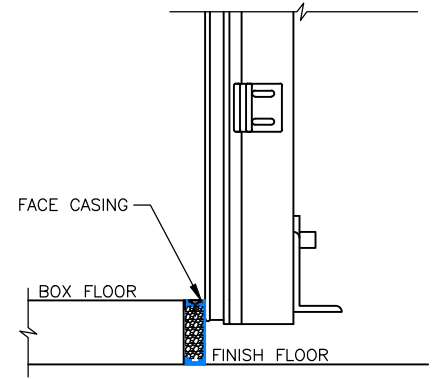

⑮ SCALE: 1" = 1'-0"

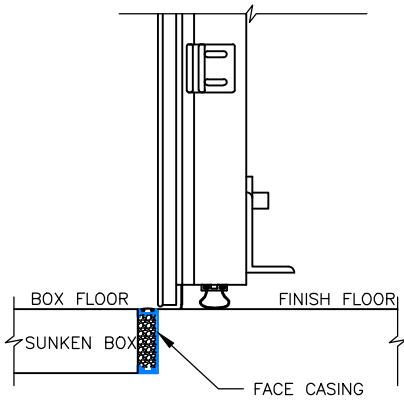

⑯ SCALE: 1" = 1'-0"

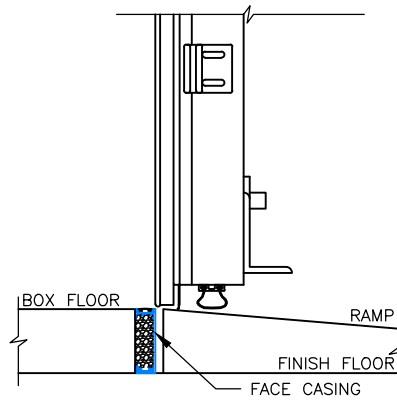

⑰ SCALE: 1" = 1'-0"

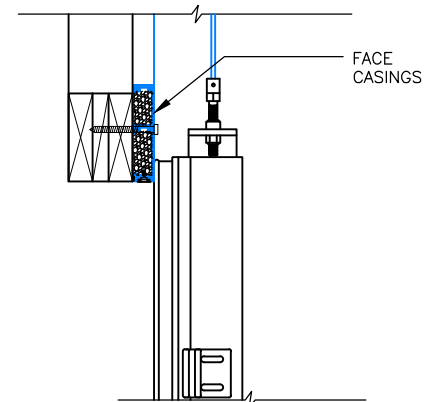

⑱ SCALE: 1" = 1'-0"

- ⑬ SILL DETAIL – SWEEP BOTTOM
- ⑭ SILL DETAIL – HIGH SILL STEP OVER
- ⑮ SILL DETAIL – HIGH SILL
- ⑯ SILL DETAIL – HIGH SILL WITH SUNKEN BOX FLOOR
- ⑰ SILL DETAIL – HIGH SILL WITH RAMP
- ⑱ HEAD – SLIDING DOOR – INSULATED METAL PANEL

